



COUPON BOOK FINISHING SYSTEMS

SIBAFLEX P

TWO CONTINUOUS WEBS PRINTED 1-UP

System Description

The Sibaflex P system is designed to produce coupon booklets with number of documents variable at random, from one (1) or two (2) continuous webs, personalized and printed 1-up.

Up to 4 cover/enclosure feeders complete the collation of each booklet with precut, non personalized documents. Stitching and spine taping are an integral part of the binding section.

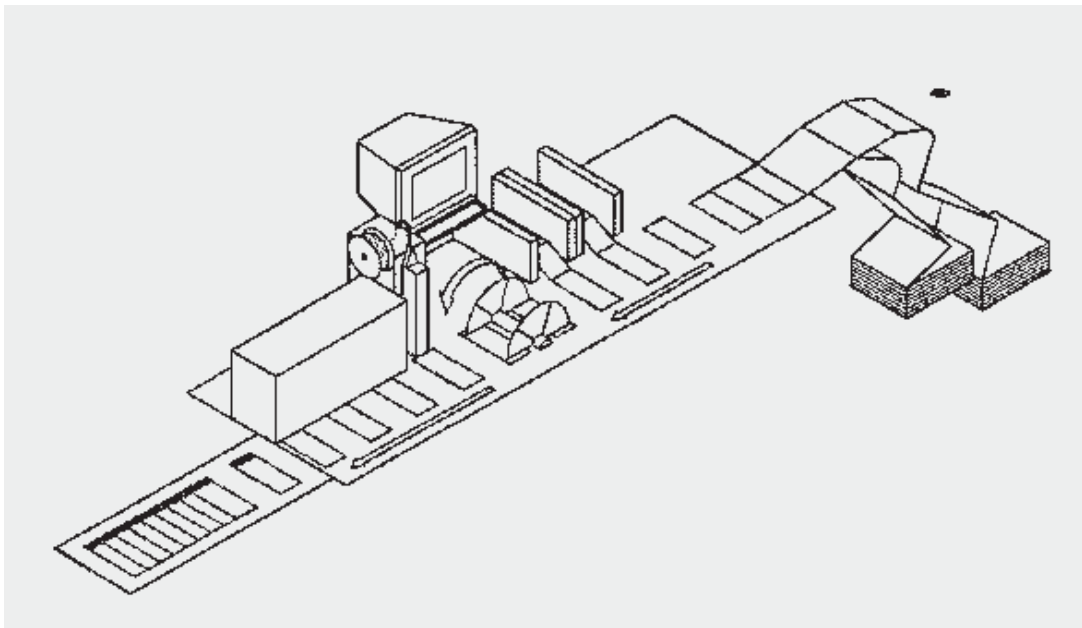

System Configuration

- Dual web cutter
- Buffering conveyor
- Collecting unit
- Cover feeders
- Jogging unit
- Stitching and spine taping unit
- Output conveyor
- Control unit

Stationery Characteristics

Coupon weight 80 to 150 gsm
Cover weight 120 - 180 gsm

Printing Criteria

Continuous stationery printed 1-up
OMR/BCR document personalization
Incremental or decremental numbering (ascending or descending sequence)

Booklet Sizes

Height 2-2/3" to 4-1/3"
Width 6-5/8" to 12"
Thickness up to 1/2"

Production Speed

Up to 2000 booklets/hour



Detail of entry cutter with dual independent transports